

Fast Switching Plastic Rectifier

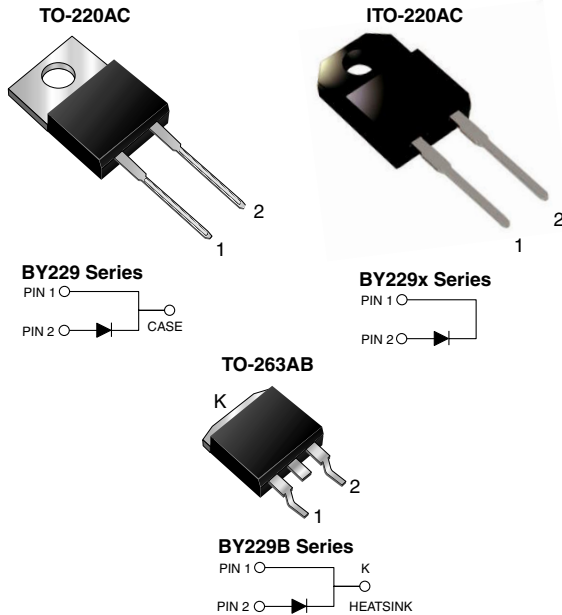

FEATURES

- Glass passivated chip junction
- Superfast recovery time for high efficiency
- Low leakage current
- High forward surge capability
- Meets MSL level 1, per J-STD-020C, LF max peak of 245 °C (for TO-263AB package)
- Solder Dip 260 °C, 40 seconds (for TO-220AC & ITO-220AC package)
- Component in accordance to RoHS 2002/95/EC and WEEE 2002/96/EC



TYPICAL APPLICATIONS

For use in fast switching rectification of power supply, inverters, converters and freewheeling diodes application.

MECHANICAL DATA

Case: TO-220AC, ITO-220AC, TO-263AB

Epoxy meets UL 94V-0 flammability rating

Terminals: Matte tin plated leads, solderable per J-STD-002B and JESD22-B102D

E3 suffix for commercial grade, HE3 suffix for high reliability grade (AEC Q101 qualified)

Polarity: As marked

Mounting Torque: 10 in-lbs maximum

MAJOR RATINGS AND CHARACTERISTICS

$I_{F(AV)}$	8.0 A
V_{RRM}	200 V to 800 V
I_{FSM}	100 A
t_{rr}	145 ns
V_F	1.85 V
$T_j \text{ max}$	150 °C

MAXIMUM RATINGS ($T_C = 25 \text{ °C}$ unless otherwise noted)

PARAMETER	SYMBOL	BY229-200	BY229-400	BY229-600	BY229-800	UNIT
Maximum recurrent peak reverse voltage	V_{RRM}	200	400	600	800	V
Maximum RMS voltage	V_{RMS}	140	280	420	560	V
Maximum DC blocking voltage	V_{DC}	200	400	600	800	V
Maximum average forward rectified current at $T_C = 100 \text{ °C}$	$I_{F(AV)}$	8.0				A
Peak forward surge current 8.3 ms single half sine-wave superimposed on rated load	I_{FSM}	100				A
Maximum slope of reverse recovery current $I_F = 2.0 \text{ A}$, $V_R = 30 \text{ V}$, $di/dt = 20 \text{ } \mu\text{s}$	dir/dt	60				A/ μs
Operating junction and storage temperature range	T_J, T_{STG}	- 40 to + 150				°C
Isolation voltage (ITO-220AC only) From terminal to heatsink $t = 1 \text{ minute}$	V_{AC}	1500				V

ELECTRICAL CHARACTERISTICS ($T_C = 25\text{ }^\circ\text{C}$ unless otherwise noted)							
PARAMETER	TEST CONDITIONS	SYMBOL	BY229-200	BY229-400	BY229-600	BY229-800	UNIT
Maximum instantaneous forward voltage ⁽¹⁾	at 20 A	V_F			1.85		V
Maximum DC reverse current at rated DC blocking voltage	$T_J = 25\text{ }^\circ\text{C}$ $T_J = 125\text{ }^\circ\text{C}$	I_R			10 300		μA
Maximum reverse recovery time	at $I_F = 1.0\text{ A}$, $V_R = 30\text{ V}$, $di/dt = 50\text{ A}/\mu\text{s}$, $I_{RR} = 10\% I_{RM}$	t_{rr}			145		ns
Maximum recovered stored charge	$I_F = 2.0\text{ A}$, $V_R = 30\text{ V}$, $di/dt = 20\text{ A}/\mu\text{s}$	Q_{rr}			700		nC

Note:

(1) Pulse test: 300 μs pulse width, 1 % duty cycle

THERMAL CHARACTERISTICS ($T_C = 25\text{ }^\circ\text{C}$ unless otherwise noted)					
PARAMETER	SYMBOL	BY229	BY229X	BY229B	UNIT
Typical thermal resistance, junction to case	$R_{\theta JC}$	2.0	4.8	2.0	$^\circ\text{C}/\text{W}$
Typical thermal resistance, junction to air	$R_{\theta JA}$	20	-	20	$^\circ\text{C}/\text{W}$

ORDERING INFORMATION					
PACKAGE	PREFERRED P/N	UNIT WEIGHT (g)	PACKAGE CODE	BASE QUANTITY	DELIVERY MODE
TO-220AC	BY229-200-E3/45	1.80	45	50/Tube	Tube
ITO-220AC	BY229X-200-E3/45	1.95	45	50/Tube	Tube
TO-263AB	BY229B-200-E3/45	1.77	45	50/Tube	Tube
TO-263AB	BY229B-200-E3/81	1.77	81	800/Reel	Tape Reel

RATINGS AND CHARACTERISTICS CURVES

($T_A = 25\text{ }^\circ\text{C}$ unless otherwise noted)

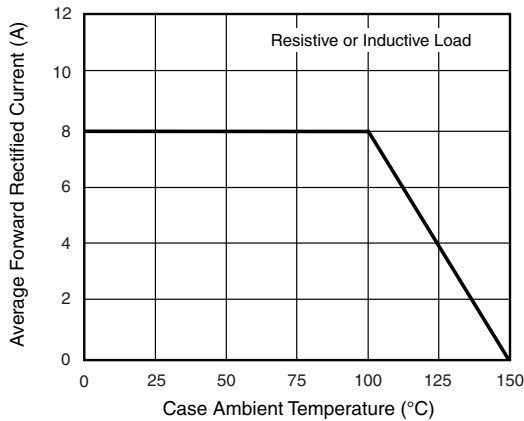

Figure 1. Forward Current Derating Curve

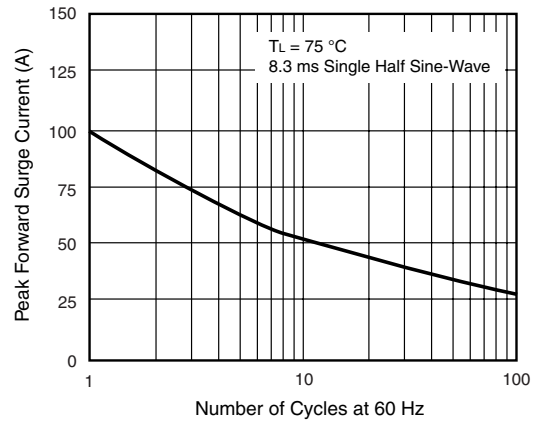

Figure 2. Maximum Non-Repetitive Peak Forward Surge Current

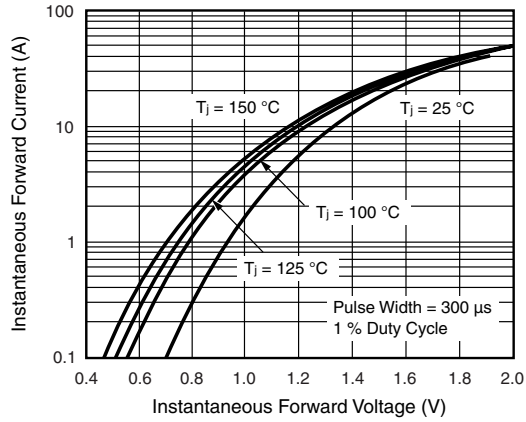

Figure 3. Typical Instantaneous Forward Characteristics

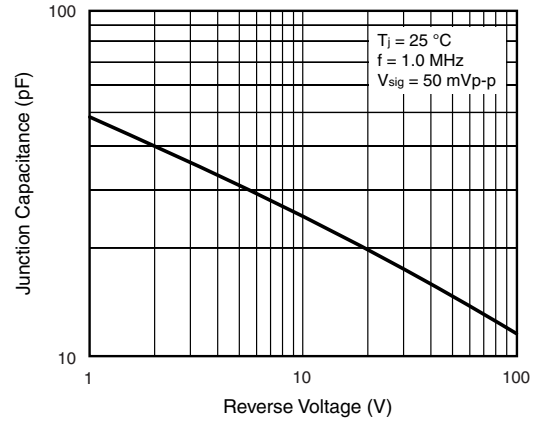

Figure 5. Typical Junction Capacitance

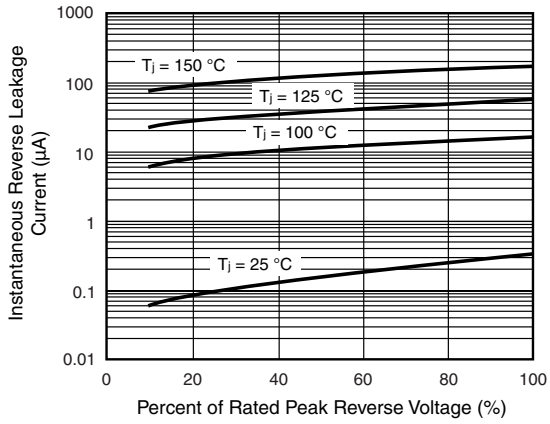

Figure 4. Typical Reverse Leakage Characteristics

BY229(X,B)-200 thru BY229(X,B)-800

Vishay General Semiconductor



PACKAGE OUTLINE DIMENSIONS in inches (millimeters)

TO-220AC

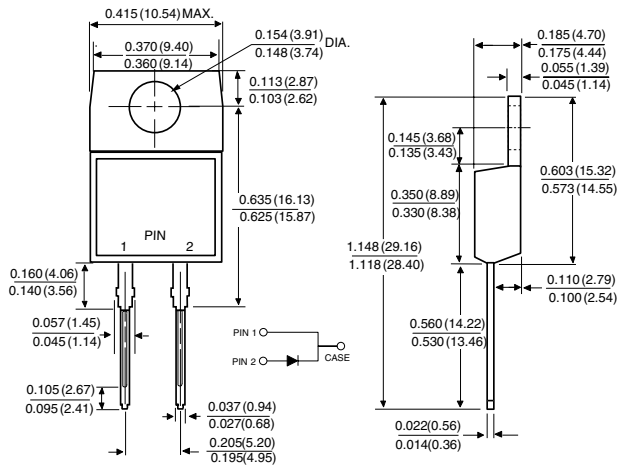

ITO-220AC

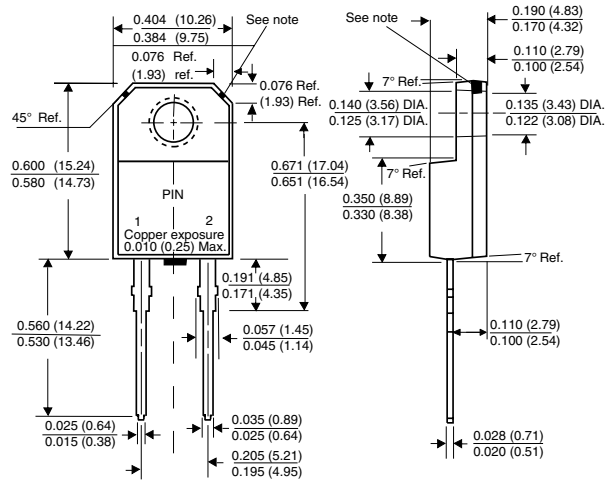

Note: Copper exposure is allowable for 0.005 (0.13) Max. from the body

TO-263AB

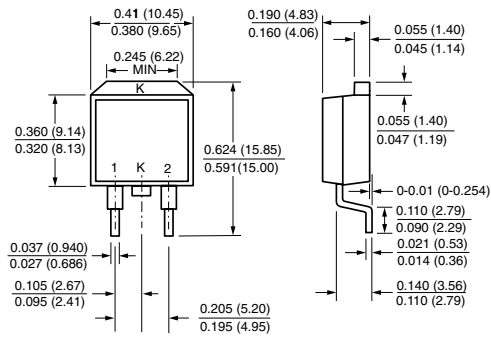

Mounting Pad Layout

