

TV Vertical Deflection Output Amplifier

Technology: Bipolar

Features

- Output peak current, $I_5 = 2\text{ A}$
- Flyback current, peak to peak, $I_3 = 3\text{ A}$
- Thermal protection, $T_j \geq 140^\circ\text{C}$

Case: 7 leads special plastic case

Block diagram

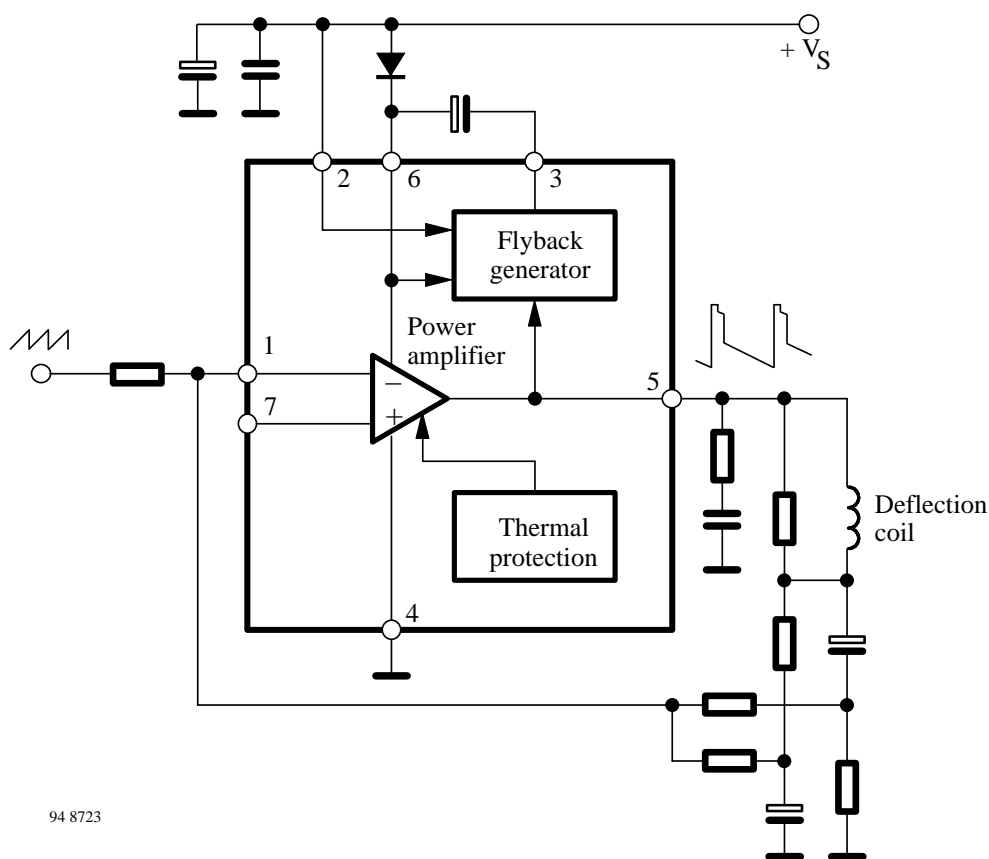

94 8723

Figure 1 Block diagram

Pin Configuration

Pin	Function
1	Inverted input
2	Supply voltage
3	Flyback generator
4	Ground

Pin	Function
5	Output
6	Output stage supply
7	Non inverted input

TEA 8172

Absolute Maximum Ratings

Parameters	Symbol	Value	Unit
Supply voltage Pin 2	V_S	35	V
Flyback peak voltage Pins 5 and 6	$V_{5,6}$	60	V
Voltage at pin 3	V_3	V_S	V
Input voltage Pins 1 and 7	$V_{1,7}$	V_S	V
Output peak current: t = 2 ms, non repetitive f = 50/60 Hz, t ≤ 10 μs f = 50/60 Hz, t > 10 μs Pin 5	I_O	2.5 3.0 2.0	A
DC current at pin 3, $V_5 < V_2$	I_3	100	mA
Flyback current peak to peak, f = 50/60 Hz, $t_{fly} \leq 1.5$ ms Pin 3	I_3	3	A
Power dissipation, $T_{case} = 70^\circ\text{C}$	P_{tot}	20	W
Storage temperature	T_{stg}	- 40 to + 150	°C
Junction temperature	T_j	- 40 to + 150	°C

Thermal Resistance

Parameters	Symbol	Maximum	Unit
Junction case	R_{thJC}	3	K/W

Electrical Characteristics

$V_S = 35$ V, $T_{amb} = 25^\circ\text{C}$, reference point Pin 4 (GND), see test circuits, unless otherwise specified

Parameters	Test Conditions / Pin	Symbol	Min	Typ	Max	Unit
Quiescent current	$I_3 = 0, I_S = 0$ Pin 2	I_2		8	16	mA
	$I_3 = 0, I_S = 0$ Pin 6 figure 2	I_6		16	36	
Input quiescent current	$V_1 = 1$ V Pin 1 figure 3	$-I_1$		0.1	1	μA
Saturation voltage to GND	$I_3 = 20$ mA Pin 3 figure 4	V_{3-4}		1	1.5	V
Output voltage	$V_S = 35$ V, $R_f = 39$ kΩ figure 5 Pin 5	V_5		18		V
Saturation voltage to GND	$I_5 = 0.7$ A Pin 5	V_{5-4}		0.7	1.0	V
	$I_5 = 1.2$ A figure 6			1.0	1.4	
Saturation voltage to supply	$I_5 = -0.7$ A Pin 5	V_{5-6}		1.3	1.8	V
	$I_5 = -1.2$ A figure 7			1.6	2.2	
Junction temperature for thermal shut down		T_j		140		°C

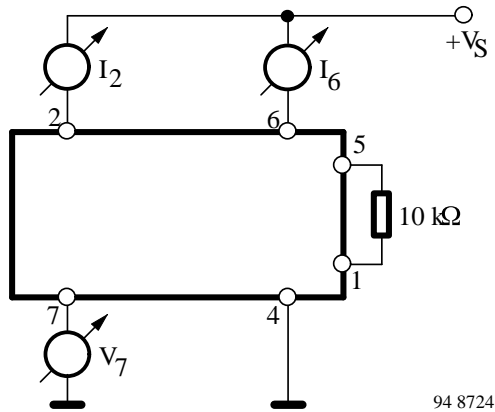

Figure 2

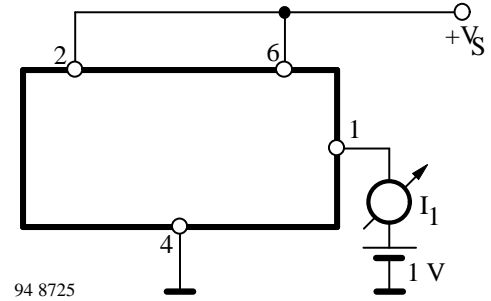

Figure 3

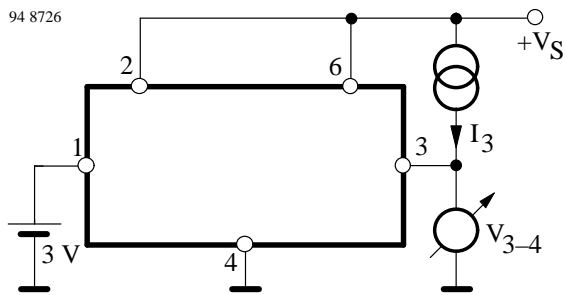

Figure 4

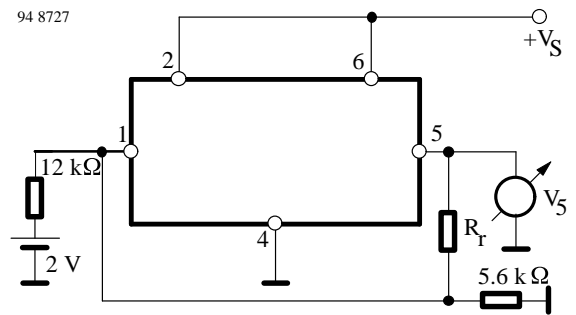

Figure 5

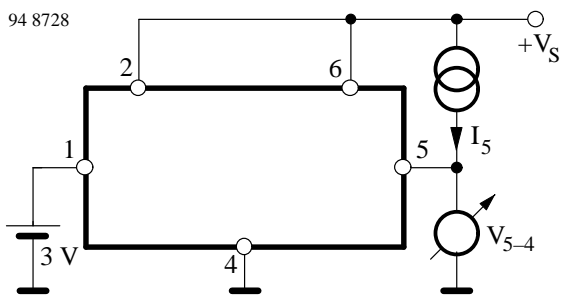

Figure 6

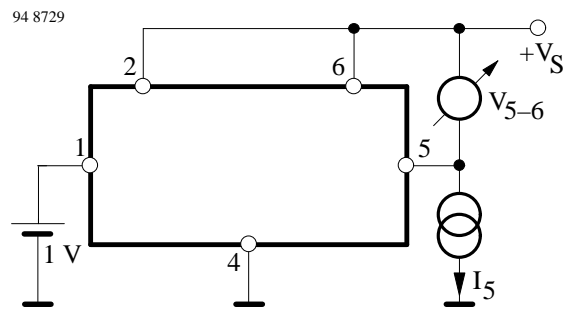
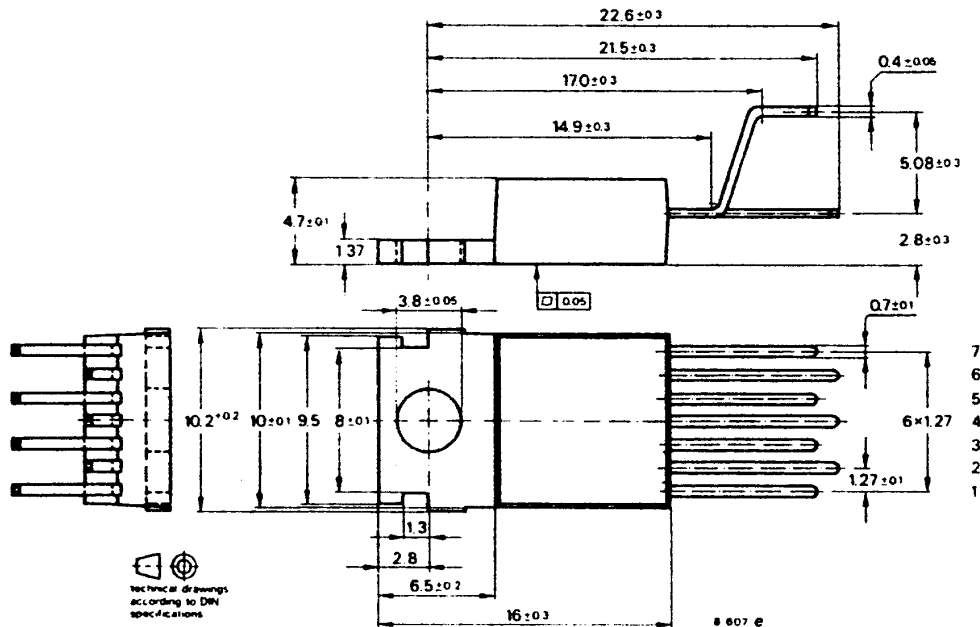

Figure 7

TEA 8172

Dimensions in mm

7 leads special plastic case



We reserve the right to make changes without further notice to improve technical design.

Parameters can vary in different applications. All operating parameters must be validated for each customer application by customer. Should Buyer use TEMIC products for any unintended or unauthorized application, Buyer shall indemnify TEMIC against all claims, costs, damages, and expenses, arising out of, directly or indirectly, any claim of personal damage, injury or death associated with such unintended or unauthorized use.

TEMIC TELEFUNKEN microelectronic GmbH, P.O.B. 3535, D-74025 Heilbronn, Germany
 Telephone: 49 (0)7131 67 2831, Fax Number: 49 (0)7131 67 2423