

## HIGH EFFICIENCY FAST RECOVERY RECTIFIER DIODES

- VERY LOW CONDUCTION LOSSES
- NEGLIGIBLE SWITCHING LOSSES
- LOW FORWARD AND REVERSE RECOVERY TIMES
- HIGH SURGE CURRENT
- THE SPECIFICATIONS AND CURVES ENABLE THE DETERMINATION OF  $t_{rr}$  AND  $I_{RM}$  AT 100°C UNDER USERS CONDITIONS

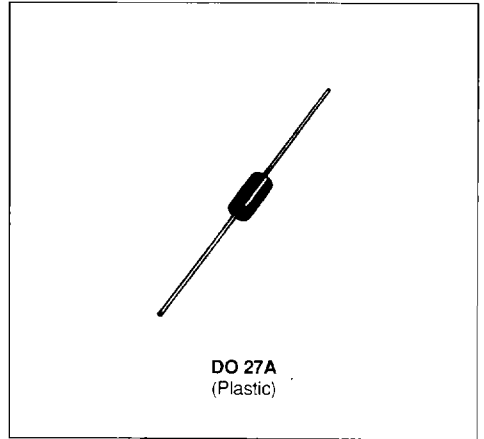

### DESCRIPTION

Low voltage drop rectifiers suited for switching mode base drive and transistor circuits.

### ABSOLUTE RATINGS (limiting values)

Symbol	Parameter		Value	Unit
$I_{FRM}$	Repetitive Peak Forward Current	$t_p \leq 20\mu s$	70	A
$I_{F(AV)}$	Average Forward Current*	$T_a = 85^\circ C$ $\delta = 0.5$	3	A
$I_{FSM}$	Surge non Repetitive Forward Current	$t_p = 10ms$ Sinusoidal	70	A
$P_{tot}$	Power Dissipation*	$T_a = 85^\circ C$	2.5	W
$T_{stg}$ $T_j$	Storage and Junction Temperature Range		- 40 to 150	°C
$T_L$	Maximum Lead Temperature for Soldering during 10s at 4mm from Case		230	°C

Symbol	Parameter	BYW 98-				Unit
		50	100	150	200	
$V_{RRM}$	Repetitive Peak Reverse Voltage	50	100	150	200	V
$V_{RSM}$	Non Repetitive Peak Reverse Voltage	55	110	165	220	V

### THERMAL RESISTANCE

Symbol	Parameter	Value	Unit
$R_{th(j-a)}$	Junction-ambient*	25	°C/W

\* On infinite heatsink with 10mm lead length

**ELECTRICAL CHARACTERISTICS**

STATIC CHARACTERISTICS

Symbol	Test Conditions		Min.	Typ.	Max.	Unit
$I_R$	$T_j = 25^\circ\text{C}$	$V_R = V_{RRM}$			10	$\mu\text{A}$
	$T_j = 100^\circ\text{C}$				0.5	$\text{mA}$
$V_F$	$T_j = 25^\circ\text{C}$	$I_F = 9\text{A}$			1.1	V
	$T_j = 100^\circ\text{C}$	$I_F = 3\text{A}$			0.85	

RECOVERY CHARACTERISTICS

Symbol	Test Conditions		Min.	Typ.	Max.	Unit
$t_{rr}$	$T_j = 25^\circ\text{C}$ $V_R = 30\text{V}$	$I_F = 1\text{A}$ See figure 10			35	ns
$Q_{rr}$	$T_j = 25^\circ\text{C}$ $V_R \leq 30\text{V}$	$I_F = 2\text{A}$		12		nC
$t_{fr}$	$T_j = 25^\circ\text{C}$ Measured at $1.1 \times V_F$	$I_F = 1\text{A}$		20		ns
$V_{FP}$	$T_j = 25^\circ\text{C}$	$I_F = 1\text{A}$		5		V

To evaluate the conduction losses use the following equations :

$$V_F = 0.66 + 0.03 I_F$$

$$P = 0.06 \times I_{F(AV)} + 0.03 I_{F(RMS)}^2$$

**PACKAGE MECHANICAL DATA**

DO 27A Plastic

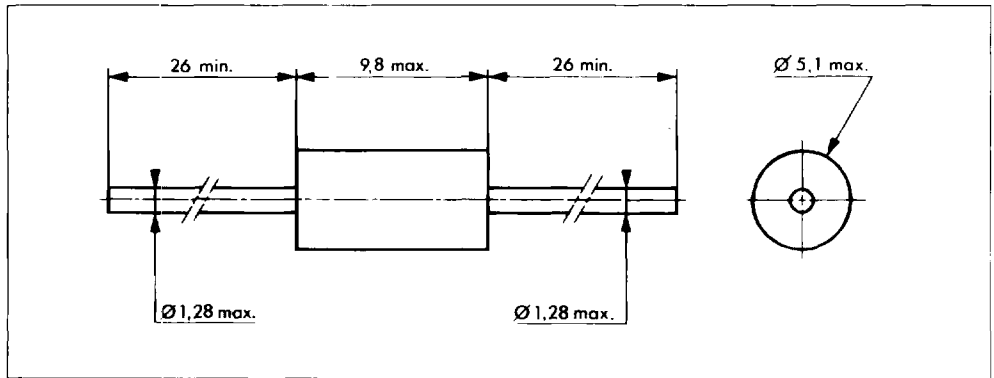

Cooling method : by convection (method A)  
 Marking : type number, white band indicates cathode  
 Weight : 1g

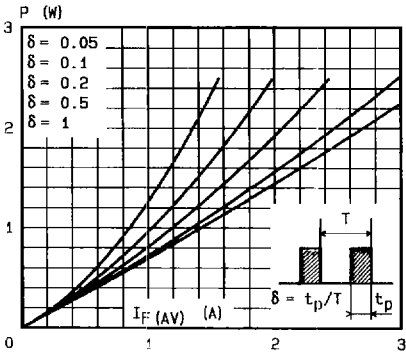

Fig.1 - Maximum average power dissipation versus average forward current.

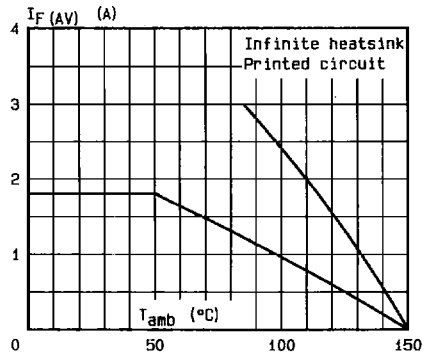

Fig.2 - Average forward current versus ambient temperature.

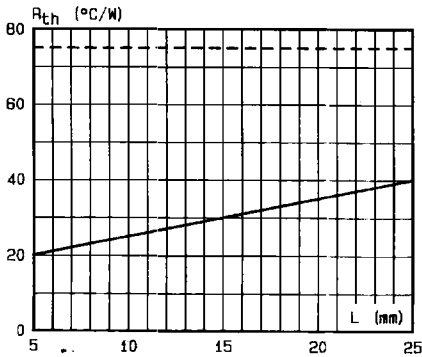

Fig.3 - Thermal resistance versus lead length.

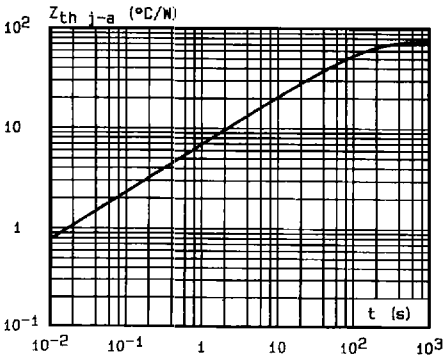
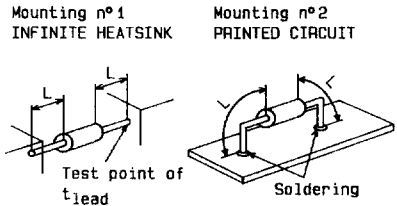

Fig.4 - Transient thermal impedance junction-ambient for mounting n°2 versus pulse duration (L = 10 mm).

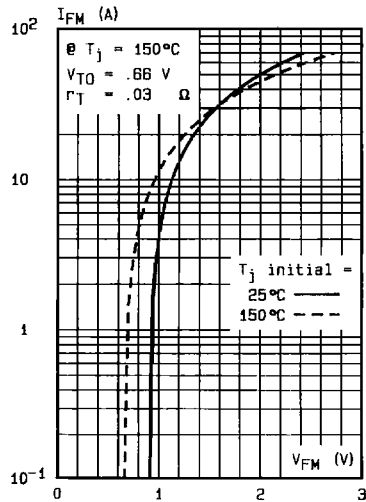

Fig.5 - Peak forward current versus peak forward voltage drop (maximum values).

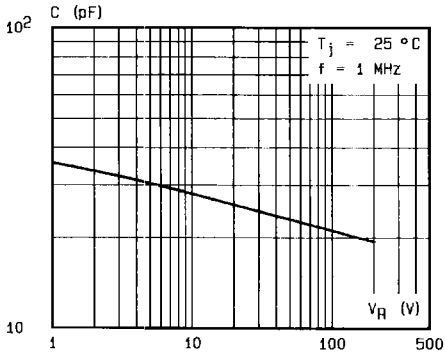

Fig. 6 - Capacitance versus reverse voltage applied.

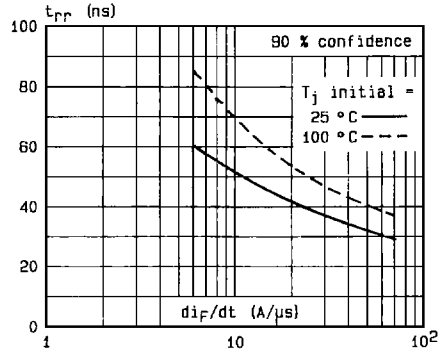

Fig. 7 - Recovery time versus  $di_F/dt$ .

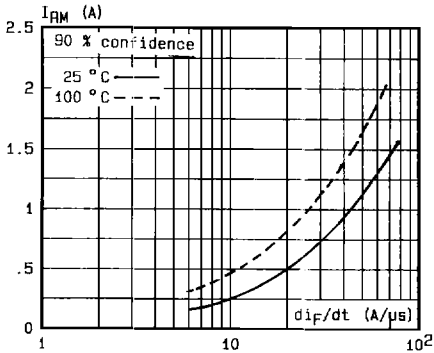

Fig. 8 - Peak reverse current versus  $di_F/dt$ .

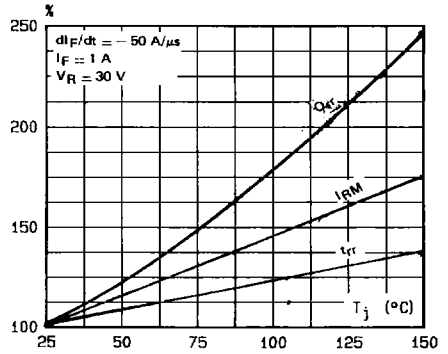

Fig. 9 - Dynamic parameters versus junction temperature.

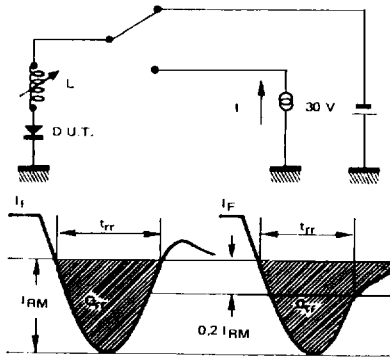

Fig. 10 - Measurement of  $t_{rr}$  (Fig. 7) and  $I_{RM}$  (Fig. 8).