

# MC14506UB

## Dual 2-Wide, 2-Input Expandable AND-OR-INVERT Gate

The MC14506UB is an expandable AND-OR-INVERT gate with inhibit and 3-state output. The expand option allows cascading with any other gate, which may be carried as far as desired as long as the propagation delay added with each gate is considered. For example, the second AOI gate in this device may be used to expand the first gate, giving an expanded 4-wide, 2-input AOI gate. This device is useful in data control and digital multiplexing applications.

- 3-State Output
- Separate Inhibit Line
- Diode Protection on All Inputs
- Supply Voltage Range = 3.0 Vdc to 18 Vdc
- Capable of Driving Two Low-Power TTL Loads or One Low-Power Schottky TTL Load Over the Rated Temperature Range

### MAXIMUM RATINGS\* (Voltages Referenced to V<sub>SS</sub>)

Symbol	Parameter	Value	Unit
V <sub>DD</sub>	DC Supply Voltage	- 0.5 to + 18.0	V
V <sub>in</sub> , V <sub>out</sub>	Input or Output Voltage (DC or Transient)	- 0.5 to V <sub>DD</sub> + 0.5	V
I <sub>in</sub> , I <sub>out</sub>	Input or Output Current (DC or Transient), per Pin	± 10	mA
P <sub>D</sub>	Power Dissipation, per Package†	500	mW
T <sub>stg</sub>	Storage Temperature	- 65 to + 150	°C
T <sub>L</sub>	Lead Temperature (8-Second Soldering)	260	°C

\* Maximum Ratings are those values beyond which damage to the device may occur.

† Temperature Derating:

Plastic "P and D/DW" Packages: - 7.0 mW/°C From 65°C To 125°C

Ceramic "L" Packages: - 12 mW/°C From 100°C To 125°C

### LOGIC DIAGRAM

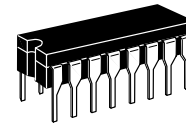
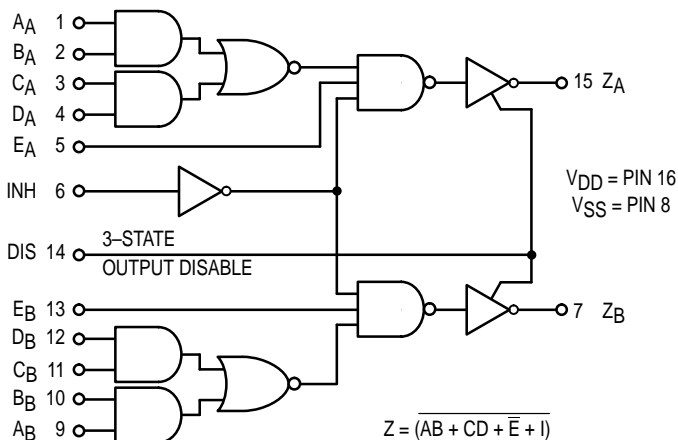

**L SUFFIX**  
CERAMIC  
CASE 620

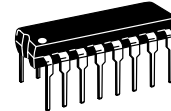

**P SUFFIX**  
PLASTIC  
CASE 648

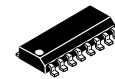

**D SUFFIX**  
SOIC  
CASE 751B

### ORDERING INFORMATION

MC14XXXUBCP	Plastic
MC14XXXUBCL	Ceramic
MC14XXXUBD	SOIC

T<sub>A</sub> = - 55° to 125°C for all packages.

This device contains protection circuitry to guard against damage due to high static voltages or electric fields. However, precautions must be taken to avoid applications of any voltage higher than maximum rated voltages to this high-impedance circuit. For proper operation, V<sub>in</sub> and V<sub>out</sub> should be constrained to the range V<sub>SS</sub> ≤ (V<sub>in</sub> or V<sub>out</sub>) ≤ V<sub>DD</sub>.

Unused inputs must always be tied to an appropriate logic voltage level (e.g., either V<sub>SS</sub> or V<sub>DD</sub>). Unused outputs must be left open.

### TRUTH TABLE

A	B	C	D	E	Inhibit	Disable	Z
0	0	0	0	1	0	0	1
0	X	0	X	1	0	0	1
0	X	X	0	1	0	0	1
X	0	0	X	1	0	0	1
X	0	X	0	1	0	0	1
1	1	X	X	X	X	0	0
X	X	1	1	X	X	0	0
X	X	X	X	0	X	0	0
X	X	X	X	X	1	0	0
X	X	X	X	X	X	1	High Impedance

X = Don't Care

**ELECTRICAL CHARACTERISTICS** (Voltages Referenced to V<sub>SS</sub>)

Characteristic	Symbol	V <sub>DD</sub> Vdc	- 55°C		25°C			125°C		Unit	
			Min	Max	Min	Typ #	Max	Min	Max		
Output Voltage V <sub>in</sub> = V <sub>DD</sub> or 0	V <sub>OL</sub>	5.0	—	0.05	—	0	0.05	—	0.05	Vdc	
		10	—	0.05	—	0	0.05	—	0.05		
15		—	0.05	—	0	0.05	—	0.05			
V <sub>in</sub> = 0 or V <sub>DD</sub>	V <sub>OH</sub>	5.0	4.95	—	4.95	5.0	—	4.95	—	Vdc	
		10	9.95	—	9.95	10	—	9.95	—		
		15	14.95	—	14.95	15	—	14.95	—		
Input Voltage (V <sub>O</sub> = 4.5 or 0.5 Vdc) (V <sub>O</sub> = 9.0 or 1.0 Vdc) (V <sub>O</sub> = 13.5 or 1.5 Vdc)	V <sub>IL</sub>	5.0	—	1.0	—	2.25	1.0	—	1.0	Vdc	
		10	—	2.0	—	4.50	2.0	—	2.0		
		15	—	2.5	—	6.75	2.5	—	2.5		
	V <sub>IH</sub>	5.0	4.0	—	4.0	2.75	—	4.0	—	Vdc	
		10	8.0	—	8.0	5.50	—	8.0	—		
		15	12.5	—	12.5	8.25	—	12.5	—		
Output Drive Current (V <sub>OH</sub> = 2.5 Vdc) (V <sub>OH</sub> = 4.6 Vdc) (V <sub>OH</sub> = 9.5 Vdc) (V <sub>OH</sub> = 13.5 Vdc)	Source	I <sub>OH</sub>	5.0	-3.0	—	-2.4	-4.2	—	-1.7	—	mAdc
			5.0	-0.64	—	-0.51	-0.88	—	-0.36	—	
			10	-1.6	—	-1.3	-2.25	—	-0.9	—	
			15	-4.2	—	-3.4	-8.8	—	-2.4	—	
	Sink	I <sub>OL</sub>	5.0	0.64	—	0.51	0.88	—	0.36	—	mAdc
			10	1.6	—	1.3	2.25	—	0.9	—	
15	4.2	—	3.4	8.8	—	2.4	—	—			
Input Current	I <sub>in</sub>	15	—	± 0.1	—	± 0.00001	± 0.1	—	± 1.0	μAdc	
Input Capacitance (V <sub>in</sub> = 0)	C <sub>in</sub>	—	—	—	—	5.0	7.5	—	—	pF	
Quiescent Current (Per Package)	I <sub>DD</sub>	5.0	—	1.0	—	0.002	1.0	—	30	μAdc	
		10	—	2.0	—	0.004	2.0	—	60		
		15	—	4.0	—	0.006	4.0	—	120		
Total Supply Current**† (Dynamic plus Quiescent, Per Package) (C <sub>L</sub> = 50 pF on all outputs, all buffers switching)	I <sub>T</sub>	5.0	I <sub>T</sub> = (0.6 μA/kHz) f + I <sub>DD</sub>							μAdc	
		10	I <sub>T</sub> = (1.1 μA/kHz) f + I <sub>DD</sub>								
		15	I <sub>T</sub> = (1.7 μA/kHz) f + I <sub>DD</sub>								
Three-State Leakage Current	I <sub>TL</sub>	15	—	± 0.1	—	± 0.0001	± 0.1	—	± 3.0	μAdc	

#Data labelled "Typ" is not to be used for design purposes but is intended as an indication of the IC's potential performance.

\*\*The formulas given are for the typical characteristics only at 25°C.

†To calculate total supply current at loads other than 50 pF:

$$I_T(C_L) = I_T(50 \text{ pF}) + (C_L - 50) Vfk$$

where: I<sub>T</sub> is in μA (per package), C<sub>L</sub> in pF, V = (V<sub>DD</sub> - V<sub>SS</sub>) in volts, f in kHz is input frequency, and k = 0.002.

**PIN ASSIGNMENT**

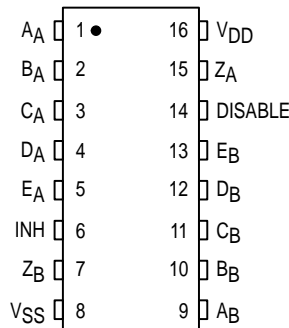

**SWITCHING CHARACTERISTICS\*** ( $C_L = 50 \text{ pF}$ ,  $T_A = 25^\circ\text{C}$ )

Characteristic	Symbol	V <sub>DD</sub>	Min	Typ #	Max	Unit
Output Rise and Fall Time $t_{TLH}, t_{THL} = (1.5 \text{ ns/pF}) C_L + 25 \text{ ns}$ $t_{TLH}, t_{THL} = (0.75 \text{ ns/pF}) C_L + 12.5 \text{ ns}$ $t_{TLH}, t_{THL} = (0.55 \text{ ns/pF}) C_L + 9.5 \text{ ns}$	$t_{TLH}, t_{THL}$	5.0 10 15	— — —	100 50 40	200 100 80	ns
Data Propagation Delay Time $t_{PLH} = (1.7 \text{ ns/pF}) C_L + 210 \text{ ns}$ $t_{PLH} = (0.66 \text{ ns/pF}) C_L + 77 \text{ ns}$ $t_{PLH} = (0.5 \text{ ns/pF}) C_L + 50 \text{ ns}$  $t_{PHL} = (1.7 \text{ ns/pF}) C_L + 185 \text{ ns}$ $t_{PHL} = (0.66 \text{ ns/pF}) C_L + 62 \text{ ns}$ $t_{PHL} = (0.5 \text{ ns/pF}) C_L + 40 \text{ ns}$	$t_{PLH}$    $t_{PHL}$	5.0 10 15  5.0 10 15	— — —  — — —	295 110 75  270 95 65	580 225 180  480 175 140	ns    ns
Expand Propagation Delay Time $t_{PLH} = (1.7 \text{ ns/pF}) C_L + 95 \text{ ns}$ $t_{PLH} = (0.66 \text{ ns/pF}) C_L + 42 \text{ ns}$ $t_{PLH} = (0.5 \text{ ns/pF}) C_L + 25 \text{ ns}$  $t_{PHL} = (1.7 \text{ ns/pF}) C_L + 115 \text{ ns}$ $t_{PHL} = (0.66 \text{ ns/pF}) C_L + 47 \text{ ns}$ $t_{PHL} = (0.5 \text{ ns/pF}) C_L + 30 \text{ ns}$	$t_{PLH}$    $t_{PHL}$	5.0 10 15  5.0 10 15	— — —  — — —	180 75 50  200 80 55	430 160 125  330 110 90	ns    ns
Inhibit Propagation Delay Time $t_{PLH} = (1.7 \text{ ns/pF}) C_L + 135 \text{ ns}$ $t_{PLH} = (0.66 \text{ ns/pF}) C_L + 67 \text{ ns}$ $t_{PLH} = (0.5 \text{ ns/pF}) C_L + 40 \text{ ns}$  $t_{PHL} = (1.7 \text{ ns/pF}) C_L + 145 \text{ ns}$ $t_{PHL} = (0.66 \text{ ns/pF}) C_L + 62 \text{ ns}$ $t_{PHL} = (0.5 \text{ ns/pF}) C_L + 35 \text{ ns}$	$t_{PLH}$    $t_{PHL}$	5.0 10 15  5.0 10 15	— — —  — — —	220 100 65  230 95 60	500 225 160  400 175 150	ns    ns
3-State Propagation Delay Time "1" to High Impedance  "0" to High Impedance  High Impedance to "1"  High Impedance to "0"	$t_{PHZ}$    $t_{PLZ}$    $t_{PZH}$    $t_{PZL}$	5.0 10 15  5.0 10 15  5.0 10 15  5.0 10 15	— — —  — — —  — — —  — — —	60 45 35  90 55 40  110 50 40  170 70 50	150 110 90  225 140 100  300 125 100  425 175 125	ns    ns    ns    ns

\* The formulas given are for the typical characteristics only at 25°C.

#Data labelled "Typ" is not to be used for design purposes but is intended as an indication of the IC's potential performance.

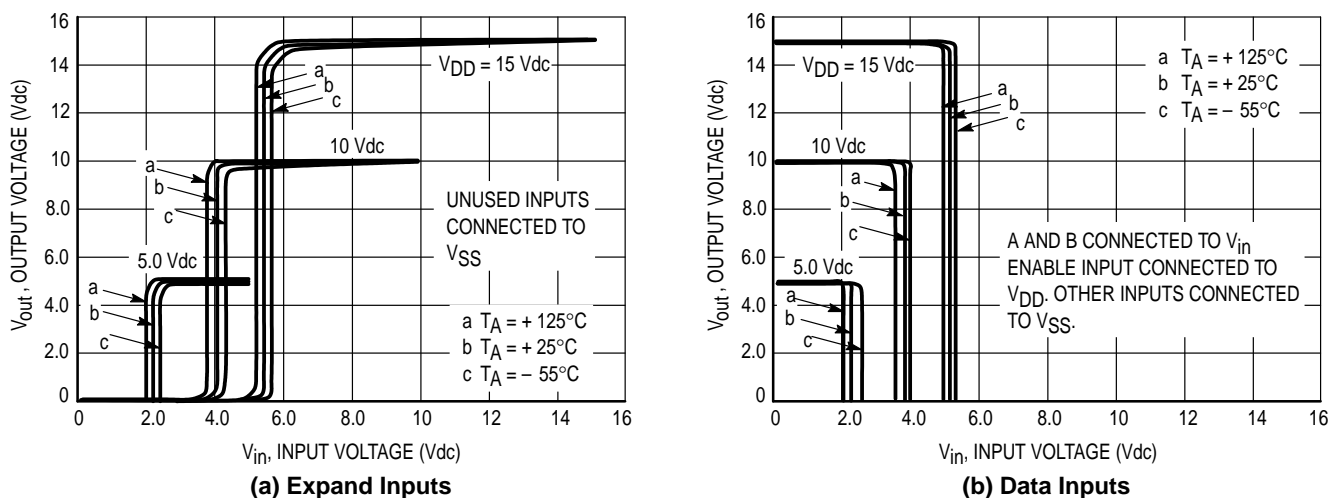

Figure 1. Typical Voltage Transfer Characteristics

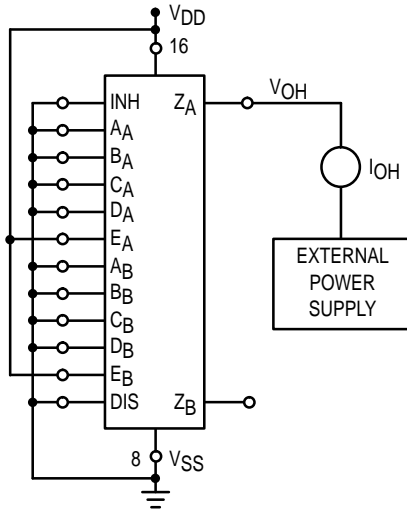

Figure 2. Typical Output Source Characteristics Test Circuit

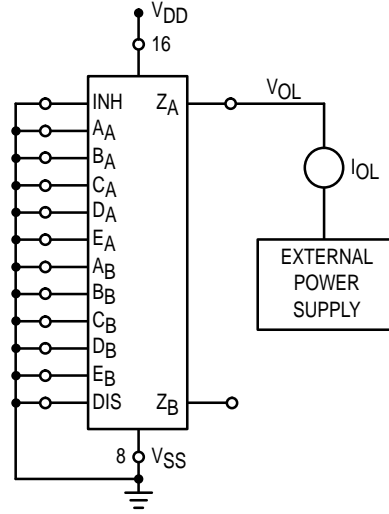

Figure 3. Typical Output Sink Characteristics Test Circuit

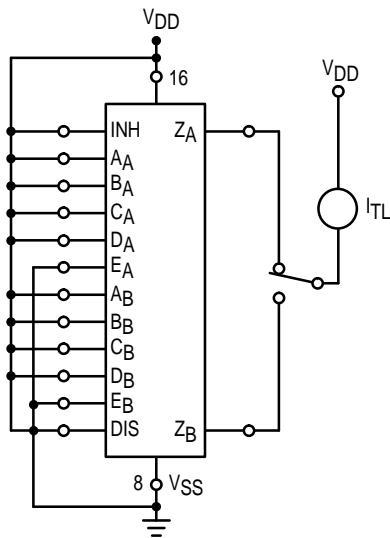

Figure 4. 3-State Leakage Current Test Circuit

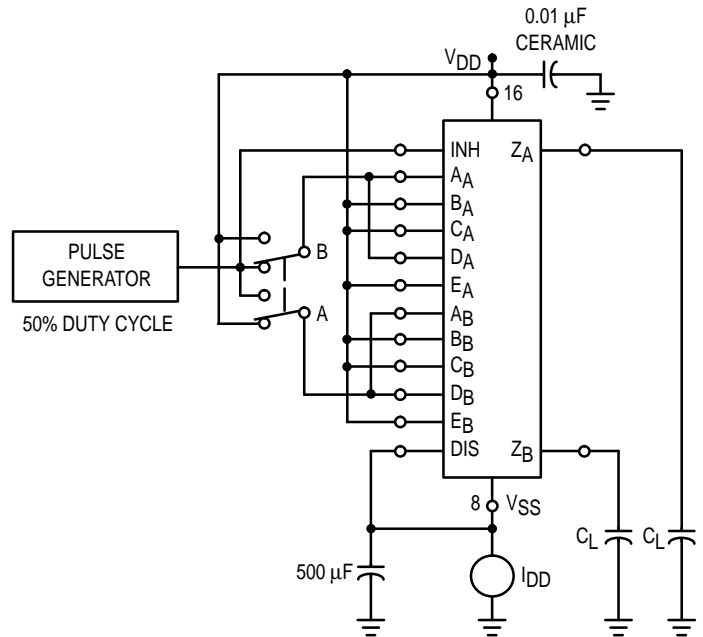

Figure 5. Typical Power Dissipation Test Circuit

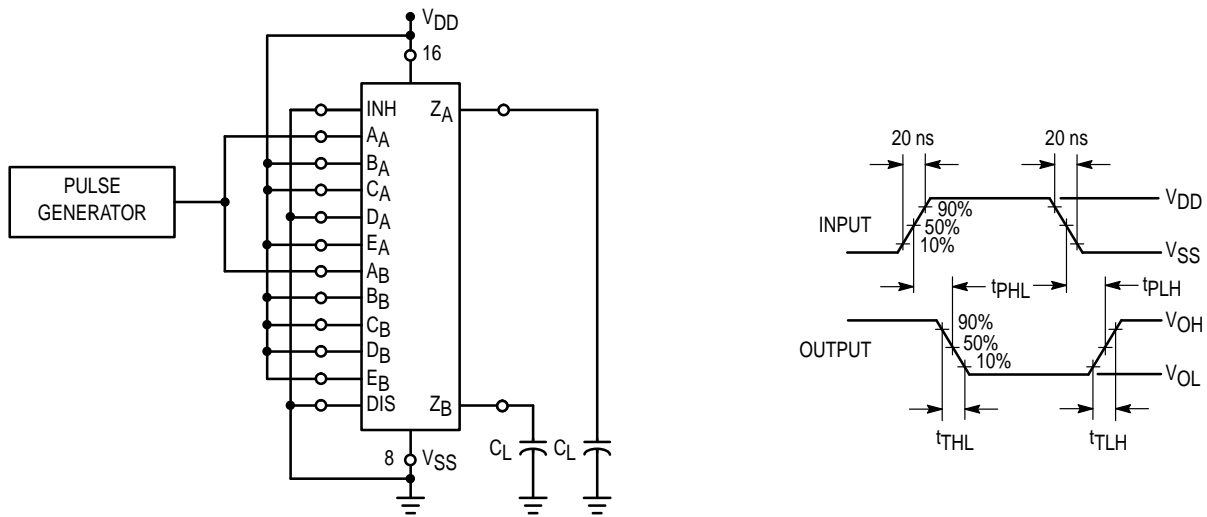
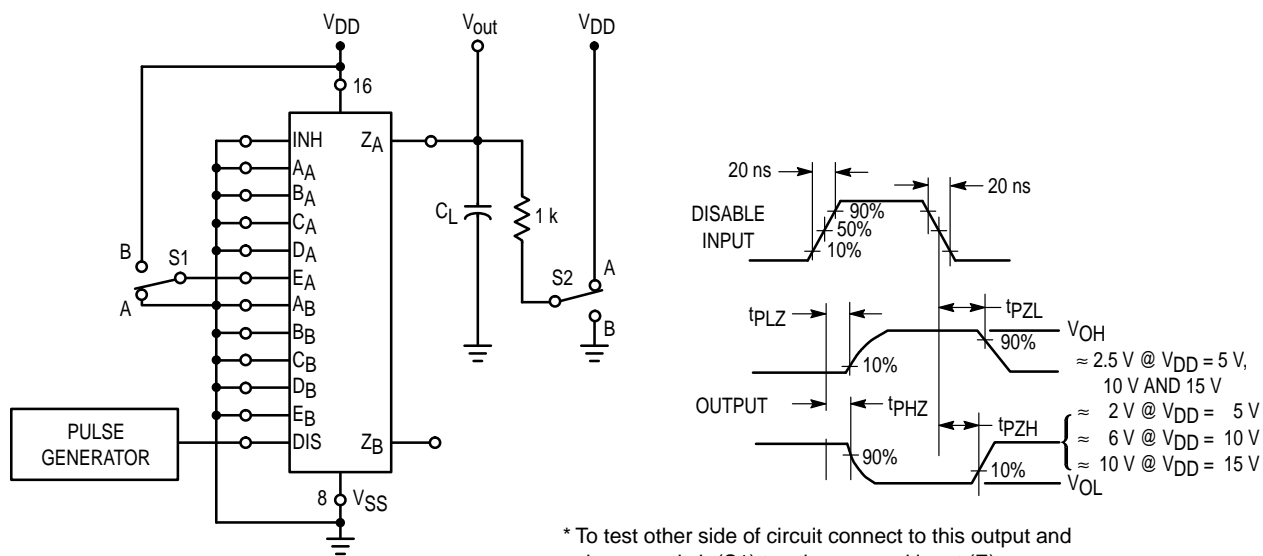

Figure 6. Switching Time Test Circuit and Waveforms (Data Inputs)



\* To test other side of circuit connect to this output and change switch (S1) to other expand input (E).

**SWITCH POSITIONS**

TEST	S1	S2
t <sub>PLZ</sub>	A	A
t <sub>PHZ</sub>	B	B
t <sub>PZL</sub>	A	A
t <sub>PZH</sub>	B	B

Figure 7. Switching Time Test Circuit and Waveforms (For 3-State Output)

## OUTLINE DIMENSIONS

### L SUFFIX CERAMIC DIP PACKAGE CASE 620-10 ISSUE V

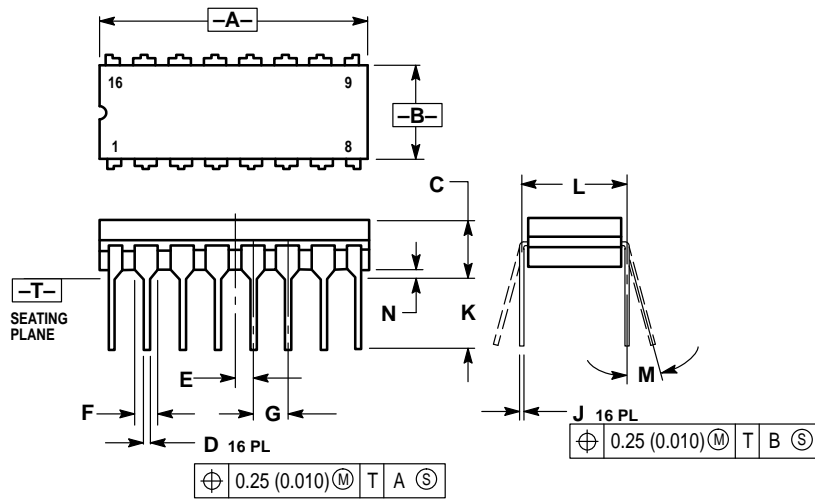

**NOTES:**

1. DIMENSIONING AND TOLERANCING PER ANSI Y14.5M, 1982.
2. CONTROLLING DIMENSION: INCH.
3. DIMENSION L TO CENTER OF LEAD WHEN FORMED PARALLEL.
4. DIMENSION F MAY NARROW TO 0.76 (0.030) WHERE THE LEAD ENTERS THE CERAMIC BODY.

DIM	INCHES		MILLIMETERS	
	MIN	MAX	MIN	MAX
A	0.750	0.785	19.05	19.93
B	0.240	0.295	6.10	7.49
C	—	0.200	—	5.08
D	0.015	0.020	0.39	0.50
E	0.050 BSC		1.27 BSC	
F	0.055	0.065	1.40	1.65
G	0.100 BSC		2.54 BSC	
H	0.008	0.015	0.21	0.38
K	0.125	0.170	3.18	4.31
L	0.300 BSC		7.62 BSC	
M	0°	15°	0°	15°
N	0.020	0.040	0.51	1.01

### P SUFFIX PLASTIC DIP PACKAGE CASE 648-08 ISSUE R

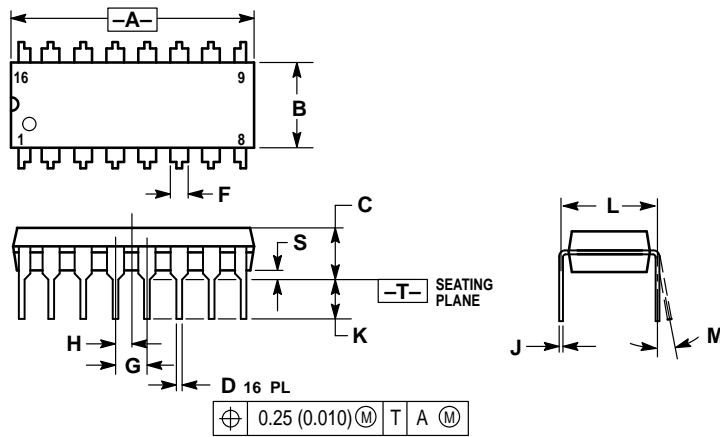

**NOTES:**

1. DIMENSIONING AND TOLERANCING PER ANSI Y14.5M, 1982.
2. CONTROLLING DIMENSION: INCH.
3. DIMENSION L TO CENTER OF LEADS WHEN FORMED PARALLEL.
4. DIMENSION B DOES NOT INCLUDE MOLD FLASH.
5. ROUNDED CORNERS OPTIONAL.

DIM	INCHES		MILLIMETERS	
	MIN	MAX	MIN	MAX
A	0.740	0.770	18.80	19.55
B	0.250	0.270	6.35	6.85
C	0.145	0.175	3.69	4.44
D	0.015	0.021	0.39	0.53
F	0.040	0.70	1.02	1.77
G	0.100 BSC		2.54 BSC	
H	0.050 BSC		1.27 BSC	
J	0.008	0.015	0.21	0.38
K	0.110	0.130	2.80	3.30
L	0.295	0.305	7.50	7.74
M	0°	10°	0°	10°
S	0.020	0.040	0.51	1.01

## OUTLINE DIMENSIONS

### D SUFFIX PLASTIC SOIC PACKAGE CASE 751B-05 ISSUE J

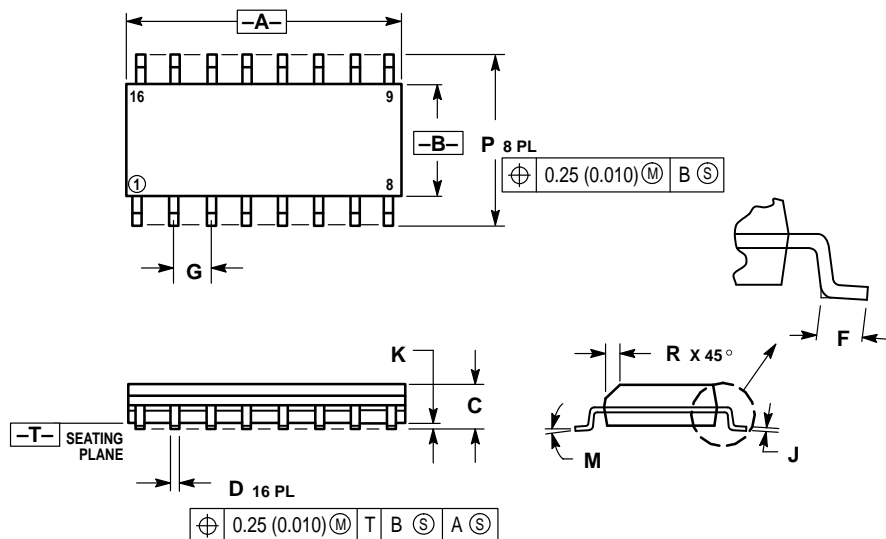

**NOTES:**

1. DIMENSIONING AND TOLERANCING PER ANSI Y14.5M, 1982.
2. CONTROLLING DIMENSION: MILLIMETER.
3. DIMENSIONS A AND B DO NOT INCLUDE MOLD PROTRUSION.
4. MAXIMUM MOLD PROTRUSION 0.15 (0.006) PER SIDE.
5. DIMENSION D DOES NOT INCLUDE DAMBAR PROTRUSION. ALLOWABLE DAMBAR PROTRUSION SHALL BE 0.127 (0.005) TOTAL IN EXCESS OF THE D DIMENSION AT MAXIMUM MATERIAL CONDITION.

DIM	MILLIMETERS		INCHES	
	MIN	MAX	MIN	MAX
A	9.80	10.00	0.386	0.393
B	3.80	4.00	0.150	0.157
C	1.35	1.75	0.054	0.068
D	0.35	0.49	0.014	0.019
F	0.40	1.25	0.016	0.049
G	1.27 BSC		0.050 BSC	
J	0.19	0.25	0.008	0.009
K	0.10	0.25	0.004	0.009
M	0°	7°	0°	7°
P	5.80	6.20	0.229	0.244
R	0.25	0.50	0.010	0.019

Motorola reserves the right to make changes without further notice to any products herein. Motorola makes no warranty, representation or guarantee regarding the suitability of its products for any particular purpose, nor does Motorola assume any liability arising out of the application or use of any product or circuit, and specifically disclaims any and all liability, including without limitation consequential or incidental damages. "Typical" parameters which may be provided in Motorola data sheets and/or specifications can and do vary in different applications and actual performance may vary over time. All operating parameters, including "Typicals" must be validated for each customer application by customer's technical experts. Motorola does not convey any license under its patent rights nor the rights of others. Motorola products are not designed, intended, or authorized for use as components in systems intended for surgical implant into the body, or other applications intended to support or sustain life, or for any other application in which the failure of the Motorola product could create a situation where personal injury or death may occur. Should Buyer purchase or use Motorola products for any such unintended or unauthorized application, Buyer shall indemnify and hold Motorola and its officers, employees, subsidiaries, affiliates, and distributors harmless against all claims, costs, damages, and expenses, and reasonable attorney fees arising out of, directly or indirectly, any claim of personal injury or death associated with such unintended or unauthorized use, even if such claim alleges that Motorola was negligent regarding the design or manufacture of the part. Motorola and are registered trademarks of Motorola, Inc. Motorola, Inc. is an Equal Opportunity/Affirmative Action Employer.

**How to reach us:**

**USA/EUROPE/Locations Not Listed:** Motorola Literature Distribution;  
P.O. Box 20912; Phoenix, Arizona 85036. 1-800-441-2447 or 602-303-5454

**JAPAN:** Nippon Motorola Ltd.; Tatsumi-SPD-JLDC, 6F Seibu-Butsuryu-Center,  
3-14-2 Tatsumi Koto-Ku, Tokyo 135, Japan. 03-81-3521-8315

**MFAX:** RMFAX0@email.sps.mot.com – TOUCHTONE 602-244-6609  
**INTERNET:** http://Design-NET.com

**ASIA/PACIFIC:** Motorola Semiconductors H.K. Ltd.; 8B Tai Ping Industrial Park,  
51 Ting Kok Road, Tai Po, N.T., Hong Kong. 852-26629298



MC14506UB/D

